

# PROXXON

**GB Service note**

All PROXXON products are thoroughly inspected after production. Should a defect occur nevertheless, please contact the dealer from whom you purchased the product. Only the dealer is responsible for handling all legal warranty claims which refer exclusively to material and manufacturer error. Improper use, such as capacity overload, damage due to outside influences and normal wear are excluded from the warranty. You will find further notes regarding "Service and Spare Parts Management" at [www.proxxon.com](http://www.proxxon.com).

# PROXXON

## TBH

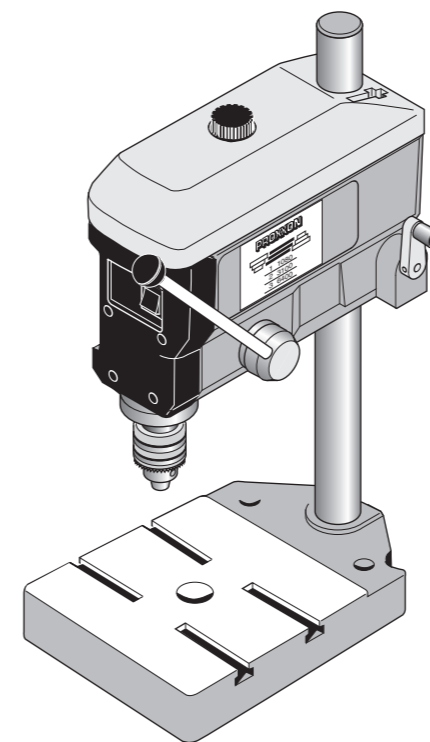

## Manual

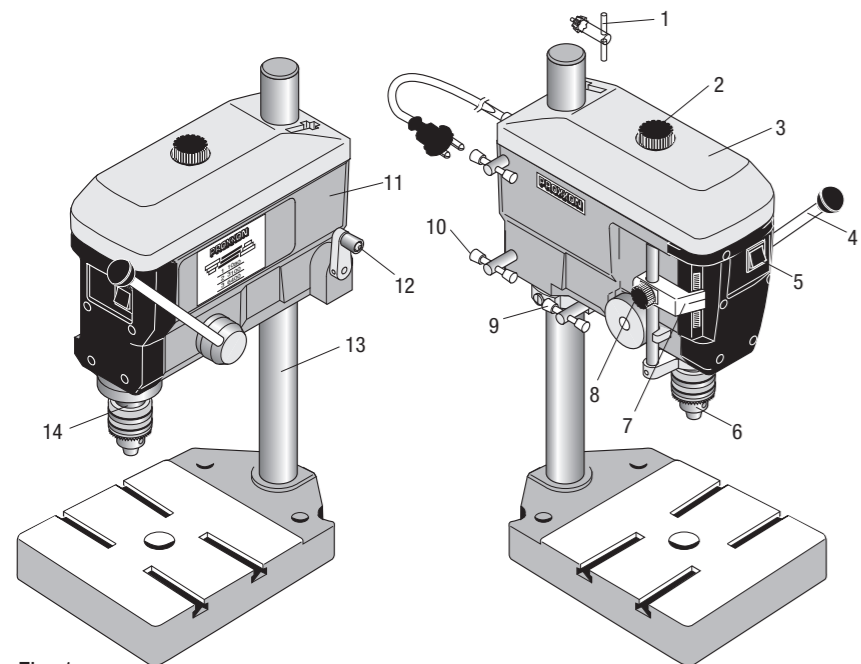

Fig. 1

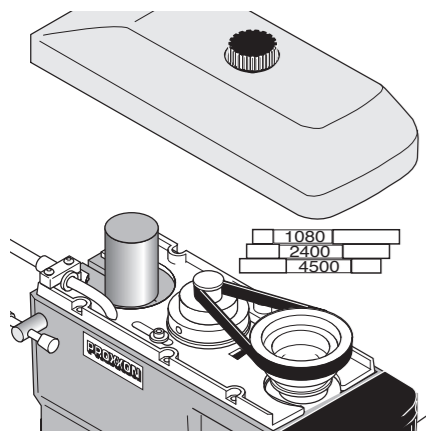

Fig. 2

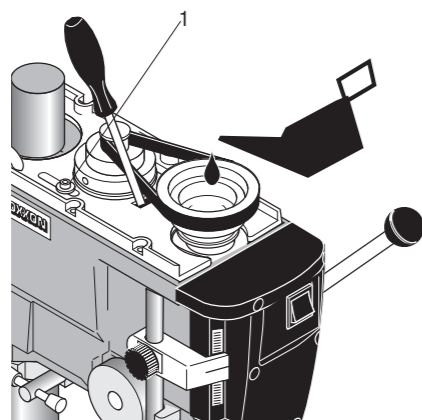
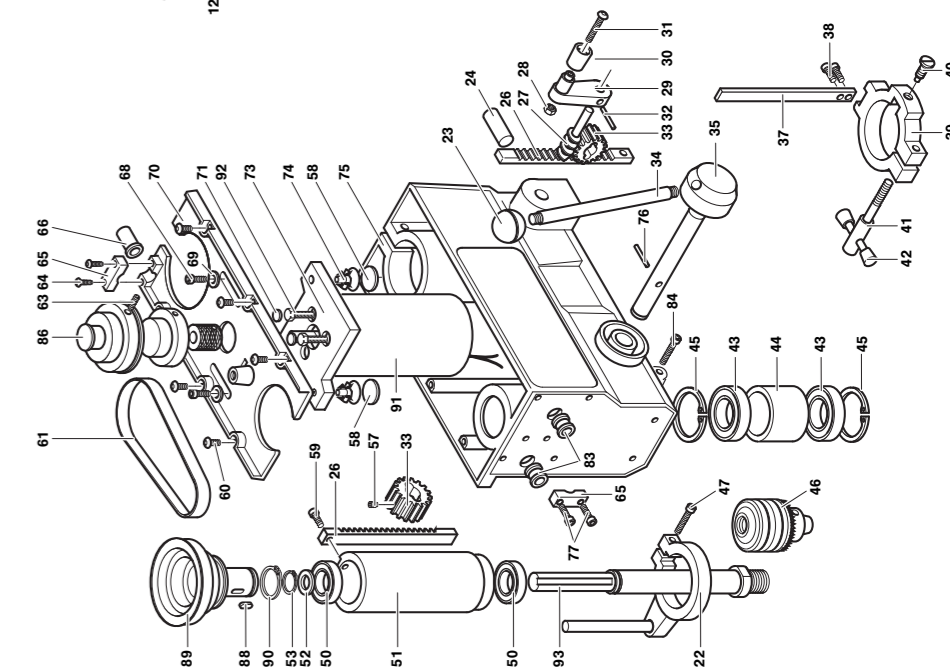
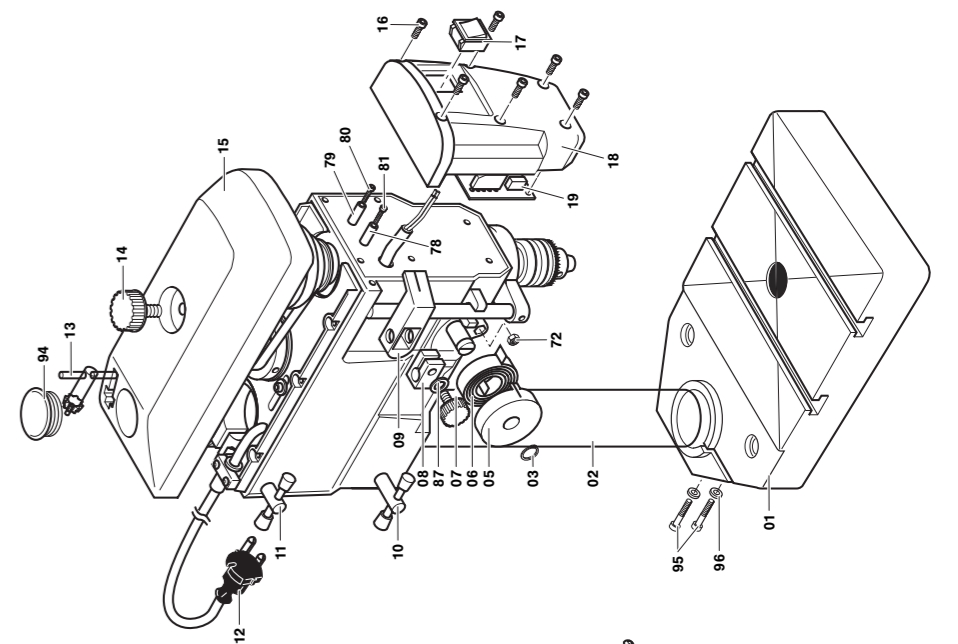

Fig. 3



Spare Parts List

TBH  
Art-No. 28124

ET-Nr.	Description	ET-Nr.	Description
28124 - 01	Drilling table	28124 - 57	Set screw
28124 - 02	Drilling column	28124 - 58	Insulating plate
28124 - 03	Circlips	28124 - 59	Screw
28124 - 05	Cover plate	28124 - 60	Screw
28124 - 06	Spiral spring	28124 - 61	Driving belt
28124 - 07	Knurled screw for pointer	28124 - 63	Set screw
28124 - 08	Clamping piece for pointer	28124 - 64	Screw
28124 - 09	Pointer	28124 - 65	Strain relief
28124 - 10	Downer T-Screw	28124 - 66	Bending protection
28124 - 11	Upper T-Screw	28124 - 68	Screw
28124 - 12	Power supply cord	28124 - 69	Washer
28124 - 13	Chuck key	28124 - 69	Washer
28124 - 14	Knurled screw	28124 - 70	Motor fixation plate
28124 - 15	Cover	28124 - 71	Insulation plate
28124 - 16	Screw	28124 - 72	Nut
28124 - 17	Switch	28124 - 73	Motor insulation plate
28124 - 18	Switch casing	28124 - 74	Drive-in nut
28124 - 19	Board	28124 - 75	Casing
28124 - 22	Flange, complete with guide bar	28124 - 76	Cylinder pin
28124 - 23	Ball handle	28124 - 77	Screw
28124 - 24	Axle	28124 - 78	Insert sleeve
28124 - 26	Gear rod	28124 - 79	Plastic spacer
28124 - 27	Worm gear	28124 - 80	PA-Screw
28124 - 28	Nut	28124 - 81	Screw
28124 - 29	Crank	28124 - 83	Plastic bushing
28124 - 30	Bushing	28124 - 84	Clamping screw for spindle
28124 - 31	Screw	28124 - 86	Insulated motor pulley
28124 - 32	Pin	28124 - 87	Washer
28124 - 33	Gear	28124 - 88	Feather key
28124 - 34	Drilling lever	28124 - 89	Pulley for drilling spindle
28124 - 35	Shaft for quill feed	28124 - 90	Circlips
28124 - 37	Guide bar	28124 - 91	Motor
28124 - 38	Screw	28124 - 92	Screw
28124 - 39	Clamping flange for column	28124 - 93	Drilling spindle
28124 - 40	Screw	28124 - 94	Cap
28124 - 41	T-screw, complete	28124 - 95	Screw
28124 - 42	Cap	28124 - 96	Washer
28124 - 43	Roller bearing	28124 - 99	Manual including safety instructions
28124 - 44	Distance ring		
28124 - 45	Circlips		
28124 - 46	Chuck with chuck key		
28124 - 47	Screw		
28124 - 50	Roller bearing		
28124 - 51	Quill		
28124 - 52	Spacer for drilling spindle		
28124 - 53	Circlips		

# Translation of the Original Operating Instructions TBH Bench Drill

Dear Customer,

The PROXXON TBH bench drill with a drill chuck range of up to 10 mm is a high-grade precision drilling tool designed for a range of industrial materials. Before using the drill, read the enclosed safety regulations and operating instructions for information on the safe and proper operation of the drill.

### **Warning!**

Read all safety warnings and instructions. Failure to follow all safety warnings and instructions listed below may result in electric shock, fire and/or serious injury.



KEEP ALL SAFETY WARNINGS AND INSTRUCTIONS FOR THE FUTURE!

## **General overview**

1. Chuck key
2. Fastening bolt for cover hood
3. Cover hood
4. Drill lever
5. On/off switch
6. Drill chuck
7. Depth display
8. Bit stop locking bolt
9. Drill column locking bolt
10. Extension arm locking bolt
11. Extension arm
12. Height adjustment crank
13. Drill column
14. Key surface (SW 17)

## **Description**

The TBH bench drill was designed for maximum precision, performance and ease of use and offers an impressive range of characteristics:

- Plano-milled workbench made of high-grade, ultra-ribbed aluminium diecast.
- Sturdy chromium-plated steel column.
- Convenient crank mechanism height adjustment as an auxiliary to centre sleeve lift.
- Lock-type bit stop with dial.
- Three-speed operation geared to drive belt position, with six-fold torque in lower speed range.
- Drill spindle with high-grade, precision ball bearings (non-free-floating).
- 10 mm drill chuck (included), plus collet chuck retainer in the spindle end (collet chucks available as accessories).

### **Technical data:**

Dimensions:	
Working radius	140 mm
Workbench	200 x 200 mm
Max. bench surface distance to drill chuck	230 mm
Centre sleeve lift	63 mm
Auxiliary height adjustment via crank	70 mm
Motor:	
Voltage	230 volt
Output	300 watt
Idle speed	1,080, 2,400 and 4,500 rpm
Cut-off	KB 5 mm
Noise level	≤70 dBA
Effective acceleration	≤ 2.5 m/s <sup>2</sup>

## **Noise/vibration information**

The information on vibration and noise emission has been determined in compliance with the prescribed standardised and normative measuring

methods and can be used to compare electrical devices and tools with each other.

These values also allow a preliminary evaluation of the loads caused by vibration and noise emissions.

### **Warning!**

Depending on the operating conditions while operating the device, the actually occurring emissions could differ from the values specified above!

Please bear in mind that the vibration and noise emission can deviate from the values given in these instructions, depending on the conditions of use of the tool. Poorly maintained tools, inappropriate working methods, different work pieces, too high a feed or unsuitable work pieces or materials or unsuitable bits and cutters (here: saw blade) can significantly increase the vibration load and noise emission across the entire work period.

To more accurately estimate the actual vibration and noise load, also take the times into consideration where the device is switched off, or is running but is not actually in use. This can clearly reduce the vibration and noise load across the entire work period.

### **Warning:**

- Ensure regular and proper maintenance of your tool
- Stop operation of the tool immediately if excessive vibration occurs!
- Unsuitable bits and cutters can cause excessive vibration and noises. Only use suitable bits and cutters!
- Take breaks if necessary when working with the device!

Please do not dispose off the machine!



Read all instructions and safety rules!



Wear safety glasses!



For your safety, always wear hearing protection while working!



## **Operation**

### **Important!**

**Ensure that the drill is securely mounted on a stable support before putting it into operation.**

### **Caution!**

**Unplug the drill before changing application tools and before all adjusting operations!**

## **Clamping bit in drill chuck**

1. Insert chuck key in drill chuck 6 (Fig. 1).
2. Turn chuck key counter-clockwise to open chuck.
3. Push bit into chuck to bit stop.
4. Turn chuck key clockwise to close chuck.

### **Note:**

Close chuck without completely securing bit to check for proper seating of bit, then secure bit tightly.

### **Important!**

**Remember to remove chuck key following chucking.**

## **Removing and installing drill chuck**

### **Note:**

We recommend collet chucks (available as accessories) for precision-true

drilling operations that the standard drill chuck is unable to perform. When using collet chucks, it is first necessary to remove the standard drill chuck.

1. Lock spindle to key surface 14 (Fig. 1) using fork spanner (SW 17).
2. To unscrew chuck (counter-clockwise) or to screw chuck in (clockwise), insert chuck key, which acts as lever.

## Tighten bit in collet chuck (accessory)

### Important!

**Tightening the collet chuck without inserting a suitable drill shank will result in damage to the collet chuck.**

1. Lock spindle to key surface 14 (Fig. 1) using fork spanner (SW 17).
2. Unscrew union nut.
3. Insert suitable collet chuck together with drill shank and tighten union nut.

### Note:

Tighten all application tools for minimal protrusion. Over-protruding shanks bend easily and result in out-of-round running.

## Set spindle speed

### Caution!

**Unplug drill before performing this operation! Never operate drill without protective cover.**

### Note:

Optimal performance results from uniform, correct speed and not from excessive pressure.

Belt position "A" (Fig. 2)	= 1,080 rpm.
Belt position "B"	= 2,400 rpm.
Belt position "C"	= 4,500 rpm.

### Note:

Once the belt is properly tensioned (between motor axle and drill spindle), you should be able to easily re-position it by hand. When changing speed, it is not necessary to re-tension the belt.

1. Unscrew knurled bolt 2 (Fig. 1) and remove cover hood 3.
2. Rotate belt pulley while pressing belt in direction of smaller diameter until belt has been released.
3. Position belt onto smaller diameter for desired speed.
4. Rotate other belt pulley, while pulling belt onto large diameter until seated properly for smooth function.
5. Install cover hood. Tighten knurled bolt 2.

## Adjusting belt tension

### Caution!

**Unplug drill before performing this operation!**

### Note:

When changing drill speed, it is not necessary to re-tension the belt. Tension belt no tighter than necessary, i.e., tighten until there is no more slack. An over-tensioned belt distends over longer periods of inactivity and reduces motor output.

1. Unscrew knurled bolt 2 (Fig. 1) and remove cover hood 3.
2. Loosen both bolts 1 (Fig. 3) by one rotation.
3. Using a screwdriver, lever out the motor to the rear (Fig. 3) until the desired belt tension has been attained.
4. Tighten both bolts.
5. Install cover hood. Tighten knurled bolt 2 (Fig. 1).

## Adjusting distance between bit and workpiece

In addition to using the centre sleeve lift (drill lift), you can set the TBH bench drill to the desired height via a quick-adjustment crank mechanism (70 mm). Adjusting the drill height does not displace the drill spindle centre mark above the bench surface. In addition, the complete unit can be moved to any position along the drill column.

Crank mechanism height adjustment:

1. Loosen knurled bolts 10 (Fig. 1).
2. Adjust extension arm to desired height using crank 12.
3. Tighten knurled bolts.

### Note:

Tighten knurled bolts to eliminate unnecessary stress on mechanism when drilling

## Re-positioning complete extension arm

### Important!

**Secure extension arm against falling.**

1. Release knurled bolts 10 (Fig. 1) and knurled bolt 9.
2. Move complete extension arm to desired position.
3. Re-tighten knurled bolts.

## Utilising depth stop

Proceed as follows to adjust the max. drilling depth:

1. Loosen locking bolt 8 (Fig. 1).
2. Lower drill spindle until bit contacts workpiece.
3. Set desired drilling depth on dial 7 and re-tighten locking bolt.

## Maintenance

### Caution!

**Unplug drill before performing any maintenance operations.**

- Lubricate centre sleeve guide (Fig. 3) every 10 operating hours using a few drops of machine oil.
- Following use, the drill must be thoroughly cleaned using a whisk or brush to remove all swarf.
- All dirt deposits on the drill must be routinely removed using a rag.
- During longer periods of inactivity, the drive belt must be removed to prevent deformation and erratic function.
- If, after it has been in use for a certain time, noises are heard on touching the tailstock quill, this indicates play in the tailstock quill, which should be taken up by slightly tightening the screw, 84 (see exploded drawing, page 30).

## Accessories

For more detailed information on accessories, please request our device catalogue from the address specified on the last page in the warranty information.

### Please note in general:

Proxxon bits and cutters have been designed to work with our machines, which makes them optimal for their use.

We will not assume any liability whatsoever for the safe and proper function of our devices when using third-party bits and cutters!

## Disposal

Please do not dispose of the device in domestic waste! The device contains valuable substances that can be recycled. If you have any questions about this, please contact your local waste management enterprise or other corresponding municipal facilities.

## EC Declaration of Conformity

Name and address: PROXXON S.A.  
6-10, Hårebiärg  
L-6868 Wecker

Product designation: TBH  
Article No.: 28124

In sole responsibility, we declare that this product conforms to the following directives and normative documents:

**EU EMC Directive 2014/30/EC**  
DIN EN 55014-1/05.2012  
DIN EN 55014-2/01.2016  
DIN EN 61000-3-2/03.2015  
DIN EN 61000-3-3/03.2014

**EU Machinery Directive 2006/42/EC**  
DIN EN 62841-1/07.2016

Date: 11.12.2017



Dipl.-Ing. Jörg Wagner

PROXXON S.A.  
Machine Safety Department

The CE document authorized agent is identical with the signatory.